

- Press the down (∇) key to move the cursor to "Create New Site", then press the ENTER key.

Enter the desired site name (You can enter a desired site name up to 20 single-byte alphanumeric characters.).

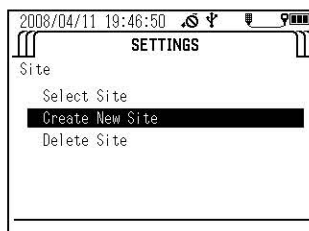

- Press the up (Δ), down (∇), right (\triangleright), and left (\triangleleft) keys to move the cursor to each letter or number to use in the name, then press the ENTER key to confirm the entered characters. To delete incorrectly entered characters, move the cursor to "BS" and press the ENTER key to start deleting from the last character. When you have finished entering the name, save it by moving the cursor to "SAVE" and pressing the ENTER key.

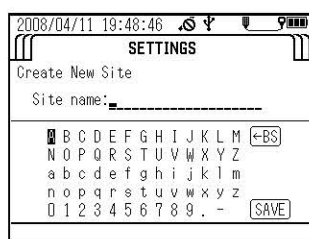

● Deleting a site

- Press the control unit's POWER key for about 1 second to turn the power ON. The "MEASUREMENT" screen appears after about 10 seconds.

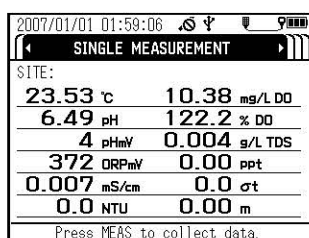

Note

The operation keys are designed to operate using the pad of a finger, sharp objects can tear the control unit cover damaging the operation keys.

- Press the right (\triangleright) key to switch the display to the "SETTINGS" screen.

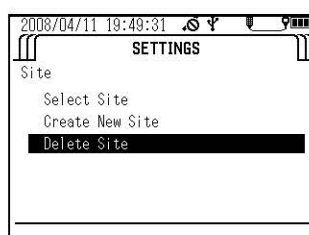

- Press the down (∇) key to move the cursor to "Site", then press the ENTER key.

4. Press the down (▽) key to move the cursor to "Delete Site", then press the ENTER key.

A list of the currently saved sites appears. The black circle (●) indicates the currently selected site.

| SINGLE MEASUREMENT | |
|-----------------------------|---------------|
| SITE: | |
| 23.53 °C | 10.38 mg/L DO |
| 6.49 pH | 122.2 % DO |
| 4 pHmV | 0.004 g/L TDS |
| 372 ORPmV | 0.00 ppt |
| 0.007 mS/cm | 0.0 σt |
| 0.0 NTU | 0.00 m |
| Press MEAS to collect data. | |

5. Press the down (▽) key to move the cursor to the site to delete, then press the ENTER key to delete it.

The currently selected site can be deleted after a different site has been selected from the site selection menu or after all unselected sites have been deleted. The same site name cannot be registered more than once.

| SETTINGS | |
|-------------|--|
| Delete Site | |
| ● AAAA | |
| • BIWAKO | |
| • KATSU | |

3.2.3 Unit for report

Note

Units can only be selected when the sensor probe is connected.

Follow the steps below to set the measurement units of measurement parameters. No units are displayed if a measurement parameter has not been selected in the measurement parameter selection screen (see "3.2.4 Sensor selection" (page 26)).

1. Press the control unit's POWER key for about 1 second to turn the power ON.
The "MEASUREMENT" screen appears after about 10 seconds.

Note

The operation keys are designed to operate using the pad of a finger, sharp objects can tear the control unit cover damaging the operation keys.

2. Press the right (▷) key to switch the display to the "SETTINGS" screen.

3. Press the down (∇) key to move the cursor to "Unit for report", then press the ENTER key.

A list of the currently selected measurement parameters and their units appears. Note that measurement parameters not selected (in the measurement parameter selection screen) are not displayed.

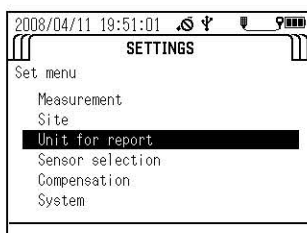

4. Press the up (Δ) and down (∇) keys to move the cursor to the item to change, then press the ENTER key.

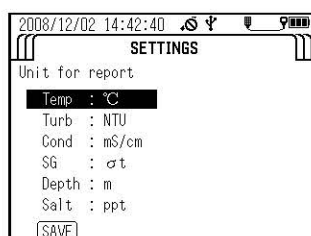

5. A list of the units that can be selected appears. The black circle (●) indicates the currently selected unit. Press the up (Δ) and down (∇) keys to move the cursor to the desired unit, then press the ENTER key.

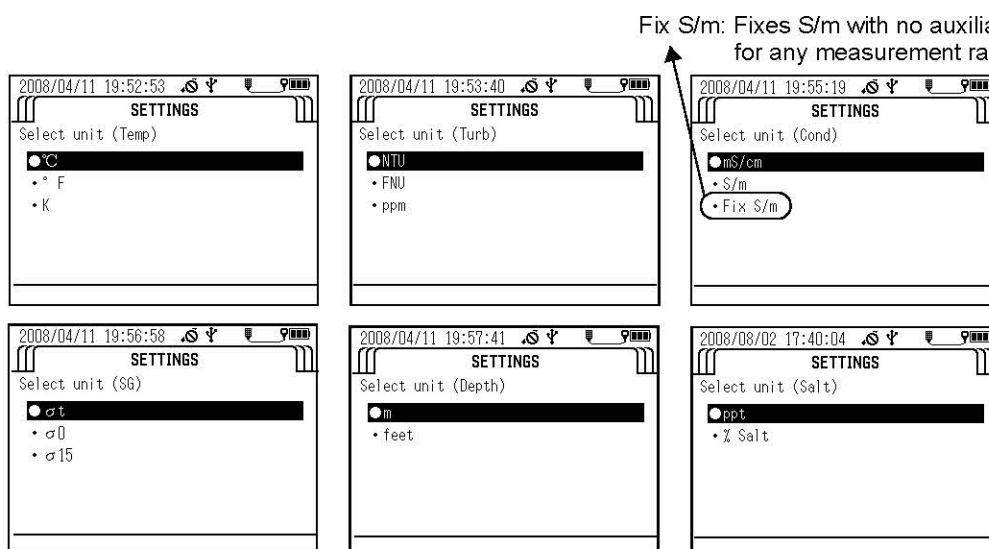

6. To save the changes, press the up (Δ) and down (∇) keys to move the cursor to SAVE, then press the ENTER key. If you do not want to save the changes, press the ESC key.

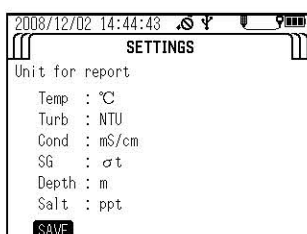

3.2.4 Sensor selection

Note

Measurement parameters can only be selected when the sensor probe is connected.

You can set between 1 and 11 measurement parameters to display in the control unit screen. Follow the steps below to select the desired measurement parameters.

1. Press the control unit's **POWER** key for about 1 second to turn the power ON. The "MEASUREMENT" screen appears after about 10 seconds.

| SINGLE MEASUREMENT | |
|--------------------|---------------|
| SITE: | |
| 23.53 °C | 10.38 mg/L DO |
| 6.49 pH | 122.2 % DO |
| 4 pHmV | 0.004 g/L TDS |
| 372 ORPmV | 0.00 ppt |
| 0.007 mS/cm | 0.0 σt |
| 0.0 NTU | 0.00 m |

Press MEAS to collect data.

Note

The operation keys are designed to operate using the pad of a finger, sharp objects can tear the control unit cover damaging the operation keys.

2. Press the right (▷) key to switch the display to the "SETTINGS" screen.
3. Press the down (▽) key to move the cursor to "Sensor selection", then press the ENTER key. A list of the measurement parameters that can be set and the currently set units are displayed.

| SETTINGS | |
|-------------------------|--|
| Set menu | |
| Measurement | |
| Site | |
| Unit for report | |
| Sensor selection | |
| Compensation | |
| System | |

4. Move the cursor to each measurement parameter to change, then press the ENTER key. A check in the check box of a measurement parameter indicates it will be displayed.
5. To save the changes, press the up (Δ), down (▽), left (◀) and right (▶) keys to move the cursor to **SAVE**, then press the ENTER key. If you don't want to save the changes, press the ESC key.

| Sensor selection | |
|--|---|
| <input checked="" type="checkbox"/> Temp : °C | <input checked="" type="checkbox"/> DO : mg/L DO |
| <input checked="" type="checkbox"/> pH : pH | <input checked="" type="checkbox"/> DO% : % DO |
| <input checked="" type="checkbox"/> pHmV : pHmV | <input checked="" type="checkbox"/> TDS : g/L TDS |
| <input checked="" type="checkbox"/> ORP : ORPmV | <input checked="" type="checkbox"/> Salt : ppt |
| <input checked="" type="checkbox"/> Cond : mS/cm | <input checked="" type="checkbox"/> SG : σt |
| <input checked="" type="checkbox"/> Turb : NTU | <input checked="" type="checkbox"/> Depth : m |
| <input type="button" value="SAVE"/> | |

Note

Available measurement parameters differ according to product specifications.

3.2.5 Compensation

Note

Compensation settings can only be made when the sensor probe is connected.

Salinity compensation and atmospheric pressure compensation for dissolved oxygen, electrical conductivity temperature conversion coefficient, and TDS coefficient settings can be configured.

● Salinity compensation (DO)

The dissolved oxygen (DO) value is presented higher than actual value if salinity compensation is not added, because the increase of salinity gives higher DO value. To obtain correct value, salinity compensation is needed. The following modes are available for calculation of salinity compensation.

AUTO: Salinity compensation is performed automatically with salinity converted from conductivity.

Value input: Press the up (Δ) and down (∇) keys to enter a setting value when the salinity is known.

1. Press the control unit's **POWER** key for about 1 second to turn the power **ON**.
The "MEASUREMENT" screen appears after about 10 seconds.

| SINGLE MEASUREMENT | |
|-----------------------------|---------------|
| SITE: | |
| 23.53 °C | 10.38 mg/L DO |
| 6.49 pH | 122.2 % DO |
| 4 pHmV | 0.004 g/L TDS |
| 372 ORPmV | 0.00 ppt |
| 0.007 mS/cm | 0.0 σt |
| 0.0 NTU | 0.00 m |
| Press MEAS to collect data. | |

Note

The operation keys are designed to operate using the pad of a finger, sharp objects can tear the control unit cover damaging the operation keys.

2. Press the right (\triangleright) key to switch the display to the "SETTINGS" screen.
3. Press the down (∇) key to move the cursor to "Compensation", then press the **ENTER** key.

| SETTINGS | |
|---------------------|--|
| Set menu | |
| Measurement | |
| Site | |
| Unit for report | |
| Sensor selection | |
| Compensation | |
| System | |

4. Press the down (∇) key to move the cursor to "DO Salinity", then press the ENTER key to toggle the setting between "Auto" and "Input mode".

Default: Auto

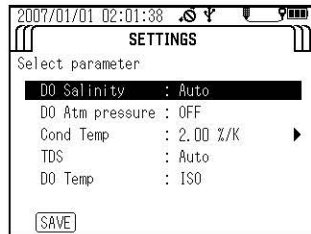

5. If you selected "Input mode", press the right (\triangleright) key to display the compensation value input screen. Press the up (Δ) and down (∇) keys to enter the desired value, then press the ENTER key to set it.

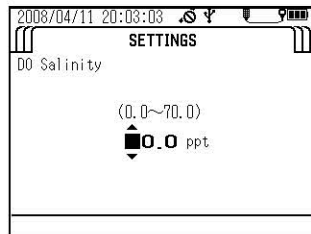

6. To save the change, press the up (Δ) and down (∇) keys to move the cursor to SAVE, then press the ENTER key. If you don't want to save the change, press the ESC key.

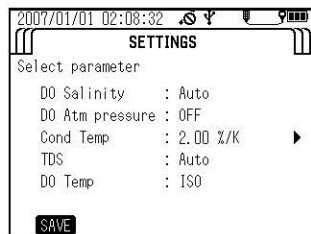

● **Atmospheric pressure compensation (DO) (In case of auto calibration)**

Differences in the atmospheric pressure of the measurement location influence the Dissolved Oxygen (DO) measurement. Influence by differences of atmospheric pressure can be compensated by calibration as follows.

- In case of manual calibration, input span calibration value considering the differences of atmospheric pressure. ("● Dissolved oxygen (DO) calibration" (page 60))
- In case of auto calibration, input actual atmospheric pressure of measurement location in this mode before the calibration.

Reference

"6.4.4 Atmospheric pressure compensation (DO) - Relation of altitude and air pressure" (page 109)

Note

- If air bubble in the internal solution is large, change the internal solution.
- Calibrate at the place of same atmospheric pressure before the measurement.

1. Press the control unit's POWER key for about 1 second to turn the power ON.

The "MEASUREMENT" screen appears after about 10 seconds.

| SINGLE MEASUREMENT | |
|--------------------|---------------|
| SITE: | |
| 23.53 °C | 10.38 mg/L DO |
| 6.49 pH | 122.2 % DO |
| 4 pHmV | 0.004 g/L TDS |
| 372 ORPmV | 0.00 ppt |
| 0.007 mS/cm | 0.0 σt |
| 0.0 NTU | 0.00 m |

Press MEAS to collect data.

Note

The operation keys are designed to operate using the pad of a finger, sharp objects can tear the control unit cover damaging the operation keys.

2. Press the right (▷) key to switch the display to the "SETTINGS" screen.

3. Press the down (▽) key to move the cursor to "Compensation", then press the ENTER key.

| SETTINGS |
|---------------------|
| Set menu |
| Measurement |
| Site |
| Unit for report |
| Sensor selection |
| Compensation |
| System |

4. Press the down (▽) key to move the cursor to "Cond Temp", then press the ENTER key to toggle the setting between "OFF" and "Input mode".

Default: OFF

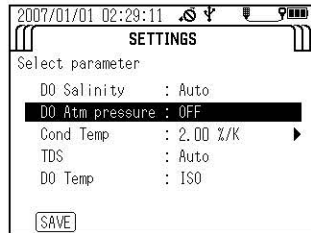

5. If you selected "Input mode", press the right (>) key to display the compensation value input screen. Press the up (Δ) and down (▽) keys to enter the desired value, then press the ENTER key to set it.

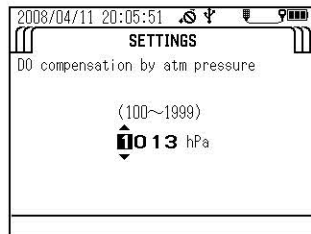

6. To save the change, press the up (Δ) and down (▽) keys to move the cursor to SAVE, then press the ENTER key. If you don't want to save the change, press the ESC key.

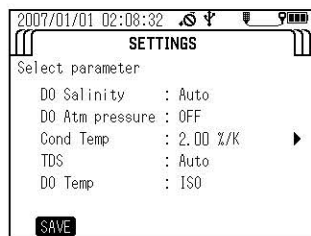

● Temperature compensation for conductivity (COND)

Sample conductivity (COND) varies with temperature, and this control unit uses a temperature compensation coefficient to automatically standardize the conductivity (COND) at 25°C. The initial setting coefficient is 2%/K, which is the generally used.

1. Press the control unit's **POWER** key for about 1 second to turn the power ON.

The "MEASUREMENT" screen appears after about 10 seconds.

| 2007/01/01 01:59:06 | |
|-----------------------------|---------------|
| SINGLE MEASUREMENT | |
| SITE: | |
| 23.53 °C | 10.38 mg/L DO |
| 6.49 pH | 122.2 % DO |
| 4 pHmV | 0.004 g/L TDS |
| 372 ORPmV | 0.00 ppt |
| 0.007 mS/cm | 0.0 σt |
| 0.0 NTU | 0.00 m |
| Press MEAS to collect data. | |

Note

The operation keys are designed to operate using the pad of a finger, sharp objects can tear the control unit cover damaging the operation keys.

2. Press the right (▶) key to switch the display to the "SETTINGS" screen.
3. Press the down (▽) key to move the cursor to "Compensation", then press the ENTER key.

| 2008/04/11 20:01:14 | |
|---------------------|--|
| SETTINGS | |
| Set menu | |
| Measurement | |
| Site | |
| Unit for report | |
| Sensor selection | |
| Compensation | |
| System | |

4. Press the down (▽) key to move the cursor to "Cond Temp", then press the ENTER key to toggle the setting between "OFF" and "Input mode".

Default: 2.00%/K

| 2007/01/01 02:29:11 | |
|---------------------|--------------|
| SETTINGS | |
| Select parameter | |
| DO Salinity | : Auto |
| DO Atm pressure | : OFF |
| Cond Temp | : 2.00 %/K ▶ |
| TDS | : Auto |
| DO Temp | : ISO |
| [SAVE] | |

5. If you selected "Input mode", press the right (\triangleright) key to display the compensation value input screen. Press the up (Δ) and down (∇) keys to enter the desired value, then press the ENTER key to set it.

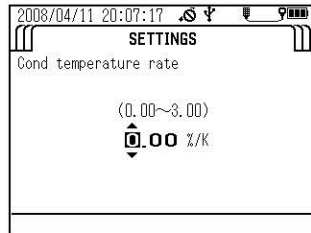

6. To save the change, press the up (Δ) and down (∇) keys to move the cursor to **SAVE**, then press the ENTER key.
If you don't want to save the change, press the ESC key.

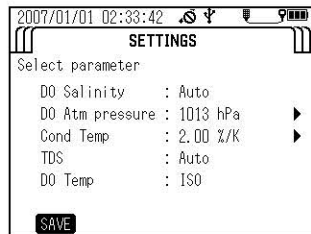

● Setting a total dissolved solid (TDS) coefficient

The total dissolved solid amount (TDS) is a converted value obtained by multiplying the conductivity (COND) by a known coefficient.

Three kinds of mode, "AUTO", "EN27888" and "Input mode", can be selected.

● AUTO

TDS is calculated according to the coefficient initially set.

The coefficient initially set for the control unit is based on a conversion for KCl and CaCO₃ solutions and it depends on the conductivity (COND) value as shown below.

| Conductivity (COND) (S/m) | Conversion coefficient |
|---------------------------|------------------------|
| < 0.05 | 0.65 |
| 0.05 to 0.5 | 0.64 |
| 0.5 to 1 | 0.63 |
| 1 to 3 | 0.62 |
| 3 to 5 | 0.61 |
| > 5 | 0.60 |

● EN27888

TDS is calculated according to the European standard "EN27888+DIN38404 (mix of most common ions in natural water)".

Note

This mode is not applicable to the conventional control unit and sensor probe.
To confirm the version, see "● Version" (page 37).

| | Control unit | Sensor probe |
|------------------------|--|--|
| Not applicable version | P2000266001D P2000266001C P2000266001B P2000266001A P2000266001- | P2000267001C P2000267001B P2000267001A P2000267001- |

● Input mode

TDS is calculated according to the entered coefficient.

1. Press the control unit's **POWER** key for about 1 second to turn the power ON.
The "MEASUREMENT" screen appears after about 10 seconds.

| SINGLE MEASUREMENT | |
|-----------------------------|---------------|
| SITE: | |
| 23.53 °C | 10.38 mg/L DO |
| 6.49 pH | 122.2 % DO |
| 4 pHmV | 0.004 g/L TDS |
| 372 ORPmV | 0.00 ppt |
| 0.007 mS/cm | 0.0 σt |
| 0.0 NTU | 0.00 m |
| Press MEAS to collect data. | |

Note

The operation keys are designed to operate using the pad of a finger, sharp objects can tear the control unit cover damaging the operation keys.

2. Press the right (▷) key to switch the display to the "SETTINGS" screen.

- Press the down (▽) key to move the cursor to "Compensation", then press the ENTER key.

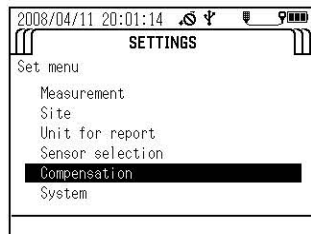

- Press the down (▽) key to move the cursor to "TDS", then press the ENTER key to switch the setting, "AUTO", "EN27888" and "Input mode".
Default: Auto

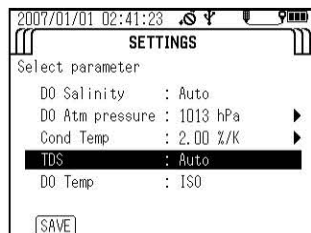

- If you selected "Input mode", press the right (▷) key to display the compensation value input screen. Press the up (△) and down (▽) keys to enter the desired value, then press the ENTER key to set it.

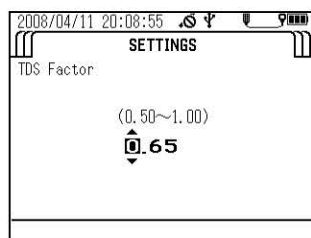

- To save the change, press the up (△) and down (▽) keys to move the cursor to SAVE, then press the ENTER key. If you don't want to save the change, press the ESC key.

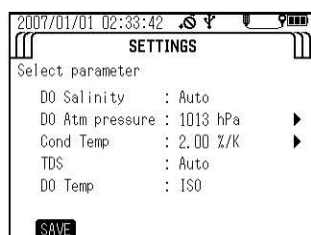

● Dissolved oxygen temperature coefficient

You can select whether to use the conventional method (JIS K 0102:2013) or the new method (ISO 5814:2012) for calculating the dissolved oxygen (DO) saturation temperature conversion coefficient.

1. Press the control unit's **POWER** key for about 1 second to turn the power ON.
The "MEASUREMENT" screen appears after about 10 seconds.

| 2007/01/01 01:59:06 | |
|-----------------------------|---------------|
| SINGLE MEASUREMENT | |
| SITE: | |
| 23.53 °C | 10.38 mg/L DO |
| 6.49 pH | 122.2 % DO |
| 4 pHmV | 0.004 g/L TDS |
| 372 ORPmV | 0.00 ppt |
| 0.007 mS/cm | 0.0 σt |
| 0.0 NTU | 0.00 m |
| Press MEAS to collect data. | |

Note

Use the pad of a finger to operate the keys. Do not use hard items such as metal rods or sharp objects such as the tips of fingernails or pens to operate the keys. Doing so may break the operation keys.

2. Press the **▷** key to display the "SETTINGS" screen.
3. Press the **▽** key to move the cursor to "Compensation", then press the **ENTER** key.

| 2008/04/11 20:01:14 | |
|---------------------|--|
| SETTINGS | |
| Set menu | |
| Measurement | |
| Site | |
| Unit for report | |
| Sensor selection | |
| Compensation | |
| System | |

4. Press the **▽** key to move the cursor to "DO Temp", then press the **ENTER** key.
Switches between ISO and Pre (ISO: ISO 5814/Pre: JIS K 0102).
Default: ISO

| 2007/01/01 02:49:39 | |
|---------------------|--------------|
| SETTINGS | |
| Select parameter | |
| DO Salinity | : Auto |
| DO Atm pressure | : 1013 hPa ▶ |
| Cond Temp | : 2.00 %/K ▶ |
| TDS | : Auto |
| DO Temp | : ISO |
| [SAVE] | |

5. To save the change, press the **△** and **▽** keys to move the cursor to **SAVE**, then press the **ENTER** key. If you do not want to save the changes, press the **ESC** key.

| 2007/01/01 02:49:39 | |
|---------------------|--------------|
| SETTINGS | |
| Select parameter | |
| DO Salinity | : Auto |
| DO Atm pressure | : 1013 hPa ▶ |
| Cond Temp | : 2.00 %/K ▶ |
| TDS | : Auto |
| DO Temp | : ISO |
| [SAVE] | |

3.2.6 System settings

The system settings let you change the display language, check the system software version, set the date/time, set the auto power OFF time, set the flicker adjustment, and initialize the settings.

● Display language

Follow the steps below to select either English or Japanese as the display language.

1. Press the control unit's **POWER** key for about 1 second to turn the power ON.
The "MEASUREMENT" screen appears after about 10 seconds.

| 2007/01/01 01:59:06 | |
|-----------------------------|---------------|
| SINGLE MEASUREMENT | |
| SITE: | |
| 23.53 °C | 10.38 mg/L DO |
| 6.49 pH | 122.2 % DO |
| 4 pHmV | 0.004 g/L TDS |
| 372 ORPmV | 0.00 ppt |
| 0.007 mS/cm | 0.0 ct |
| 0.0 NTU | 0.00 m |
| Press MEAS to collect data. | |

Note

The operation keys are designed to operate using the pad of a finger, sharp objects can tear the control unit cover damaging the operation keys.

2. Press the right (▷) key to switch the display to the "SETTINGS" screen.
3. Press the down (▽) key to move the cursor to "System", then press the ENTER key.

| 2008/04/11 20:10:18 | |
|---------------------|--|
| SETTINGS | |
| Set menu | |
| Measurement | |
| Site | |
| Unit for report | |
| Sensor selection | |
| Compensation | |
| System | |

4. Press the down (▽) key to move the cursor to "Language", then press the ENTER key.

| 2007/01/01 00:24:00 | |
|---------------------|--|
| SETTINGS | |
| System | |
| Language | |
| Version | |
| Date/Time | |
| Auto power off | |
| Flicker adjustment | |
| Initialize | |
| ▼ | |

- A list of the supported display languages appears. Press the up (Δ) and down (∇) keys to move the cursor to the desired language, then press the ENTER key.

The black circle (●) indicates the currently selected display language.



● Version

Follow the steps below to display the program No. and version of the control unit and sensor probe software.

The program No. and version of the sensor probe software will not be displayed if the sensor probe is not connected.

- Press the control unit's POWER key for about 1 second to turn the power ON. The "MEASUREMENT" screen appears after about 10 seconds.

2007/01/01 01:59:06

SINGLE MEASUREMENT

SITE:

| | |
|-------------|---------------|
| 23.53 °C | 10.38 mg/L DO |
| 6.49 pH | 122.2 % DO |
| 4 pHmV | 0.004 g/L TDS |
| 372 ORPmV | 0.00 ppt |
| 0.007 mS/cm | 0.0 σt |
| 0.0 NTU | 0.00 m |

Press MEAS to collect data.

Note

The operation keys are designed to operate using the pad of a finger, sharp objects can tear the control unit cover damaging the operation keys.

- Press the right (\triangleright) key to switch the display to the "SETTINGS" screen.
- Press the down (∇) key to move the cursor to "System", then press the ENTER key.

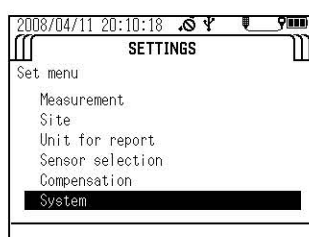

4. Press the down (▽) key to move the cursor to "Version", then press the ENTER key. The program No. of the control unit and sensor probe software appears.

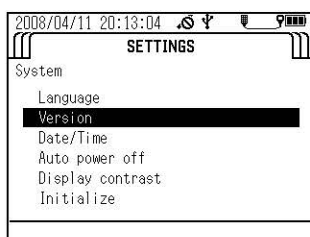

● **Setting the date/time**

Follow the steps below to set the date and time.

1. Press the control unit's POWER key for about 1 second to turn the power ON. The "MEASUREMENT" screen appears after about 10 seconds.

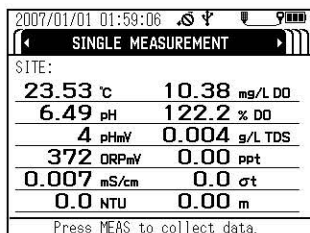

Note

The operation keys are designed to operate using the pad of a finger, sharp objects can tear the control unit cover damaging the operation keys.

2. Press the right (▷) key to switch the display to the "SETTINGS" screen.
3. Press the down (▽) key to move the cursor to "System", then press the ENTER key.

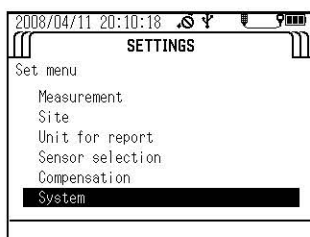

4. Press the down (▽) key to move the cursor to "Date/time", then press the ENTER key.

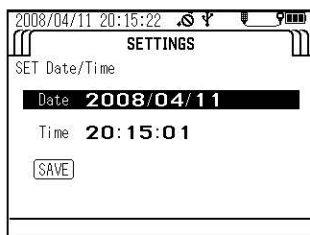

5. Move the cursor to the date, then press the ENTER key.
6. Press the right (▷) key to move the cursor to the year, month, day, hour, minute and second, and press the up (Δ) and down (▽) keys to enter each value.

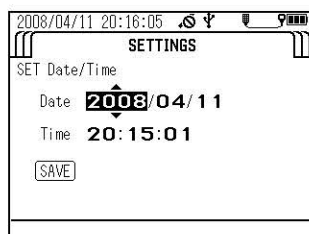

7. When finished entering settings, press the ENTER key to move the cursor to SAVE, then press the ENTER key again to save the settings.

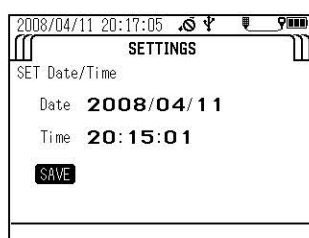

● Setting the auto power OFF time

Follow the steps below to set the time for the auto power OFF function (which turns the power OFF automatically when no operation is performed for the preset amount of time).

1. Press the control unit's POWER key for about 1 second to turn the power ON.
The "MEASUREMENT" screen appears after about 10 seconds.

| SINGLE MEASUREMENT | |
|--------------------|---------------|
| SITE: | |
| 23.53 °C | 10.38 mg/L DO |
| 6.49 pH | 122.2 % DO |
| 4 pHmV | 0.004 g/L TDS |
| 372 ORPmV | 0.00 ppt |
| 0.007 mS/cm | 0.0 σt |
| 0.0 NTU | 0.00 m |

Press MEAS to collect data.

Note

The operation keys are designed to operate using the pad of a finger, sharp objects can tear the control unit cover damaging the operation keys.

2. Press the right (▷) key to switch the display to the "SETTINGS" screen.
3. Press the down (▽) key to move the cursor to "System", then press the ENTER key.

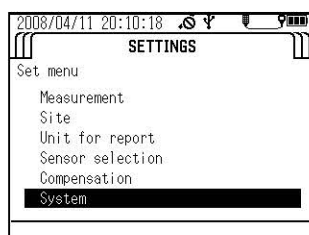

4. Press the down (▽) key to move the cursor to "Auto power off", then press the ENTER key.

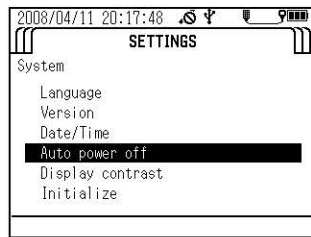

5. Press the up (△) and down (▽) keys to select the desired time setting, then press the ENTER key.
You can select OFF, or settings of 1, 2, 5, 10, 20, 30 or 60 minutes.
Default: 30 minutes

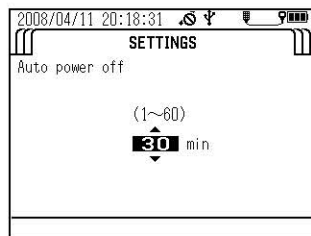

● **Flicker adjustment**

If the LCD display flickers, perform flicker adjustment.

1. Press the control unit's POWER key for about 1 second to turn the power ON.
The "MEASUREMENT" screen appears after about 10 seconds.

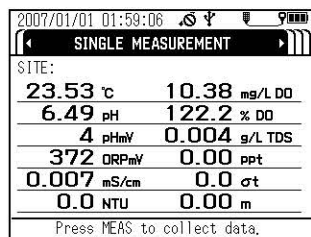

Note

The operation keys are designed to operate using the pad of a finger, sharp objects can tear the control unit cover damaging the operation keys.

2. Press the right (▷) key to switch the display to the "SETTINGS" screen.
3. Press the down (▽) key to move the cursor to "System", then press the ENTER key.

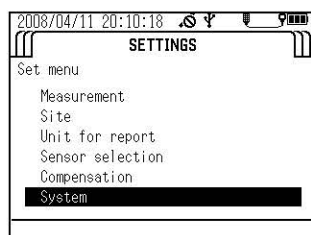

- Press the down (▽) key to move the cursor to "Flicker adjustment", then press the ENTER key.

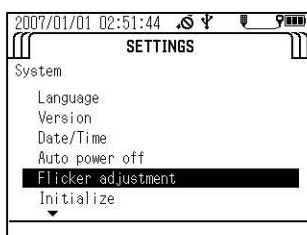

- Press the left (◀) and right (▶) keys to adjust the screen so that there is no flicker. Adjustment can be made in 36 steps.

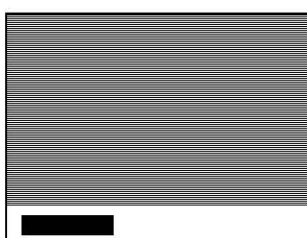

- Press the ENTER key.

● Initialization

Follow the steps below to restore all the settings except date/time to their factory defaults. Factory default calibration data for the electrical conductivity and turbidity sensors will also be deleted at the same time.

- Press the control unit's **POWER** key for about 1 second to turn the power ON. The "MEASUREMENT" screen appears after about 10 seconds.

A screenshot of the 'SINGLE MEASUREMENT' screen. The title is 'SINGLE MEASUREMENT'. The data is as follows:

| | |
|-------------|---------------|
| SITE: | |
| 23.53 °C | 10.38 mg/L DO |
| 6.49 pH | 122.2 % DO |
| 4 pHmV | 0.004 g/L TDS |
| 372 ORPmV | 0.00 ppt |
| 0.007 mS/cm | 0.0 σt |
| 0.0 NTU | 0.00 m |

At the bottom, it says 'Press MEAS to collect data.'

Note

The operation keys are designed to operate using the pad of a finger, sharp objects can tear the control unit cover damaging the operation keys.

- Press the right (▶) key to switch the display to the "SETTINGS" screen.
- Press the down (▽) key to move the cursor to "System", then press the ENTER key.

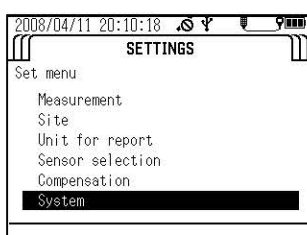

4. Press the down (▽) key to move the cursor to "Initialize", then press the ENTER key.



5. Press the ENTER key again.

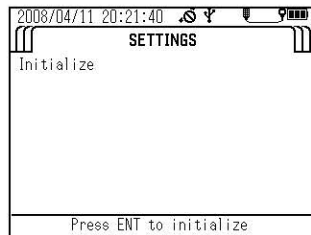

6. A confirmation message appears asking whether to execute initialization. Press the left (◀) key to move the cursor to YES, then press the ENTER key.
The message "Initialize Complete" appears to indicate the process has finished.

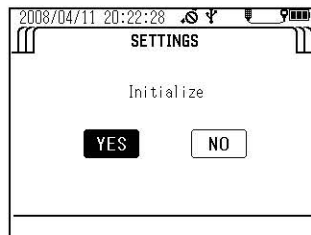

3.3 Calibration

To obtain correct measurement values, the sensors need to be calibrated using standard solution before measurement. You can select simultaneous auto calibration of the pH, COND and TURB sensors in pH4 standard solution and DO and DEP sensors simultaneously in air, or manual calibration of individual measurement parameters. You can check the result of the previous calibration using the procedure on “ 3.5.4 Checking the calibration record ” (page 74).

Note

- Wait at least 30 minutes after turning the system power ON before calibrating the DO sensor.
- Make the DO and COND compensation settings before calibration since these settings are applied during calibration.
- You can select only the desired parameters for calibration and calibrate just those parameters (see “ 3.2.4 Sensor selection ” (page 26)).
- Use about 200 mL of standard solution in the calibration cup.
- Calibration data is stored in the sensor probe.

3.3.1 Auto calibration

Tip

- The following parameters are calibrated (at 25°C):
 pH: Set to 4.01 (zero-point calibration); the span is adjusted to the factory default value or the latest calibration result.
 COND: 0.449 S/m (4.49 mS/cm, span calibration); the zero point is adjusted to the factory default value or the latest calibration result.
 TURB: 0 NTU (zero-point calibration); the span is adjusted to the factory default value or the latest calibration result.
 DO: 9.09 mg/L (when Dissolved oxygen temperature coefficient is ISO), 8.92 mg/L (when Dissolved oxygen temperature coefficient is Pre) (span calibration); the zero point is adjusted to the factory default value or the latest calibration result.
- DO%: 110% DO (span calibration): the zero point is adjusted to the factory default value or the latest calibration result.
 DEP: 0 m (zero-point calibration); the span is adjusted to the factory default value.
- If the air temperature changes, the readout value may not be stable. Ensure that the ambient air temperature is the same temperature as the calibration solution, because the internal probe temperature sensor and external temperature sensor (in the calibration solution) are used for the auto calibration. Allow the probe and standard solution to equilibrate for 1 hour if a thermometer is not available to verify that these temperatures are the same.
- Do not hold the probe while performing the auto calibration. Body temperature may elevate the internal temperature sensor measurement creating DO calibration error.

1. Remove the sensor guard and wash the sensor probe 2 or 3 times with deionized water.

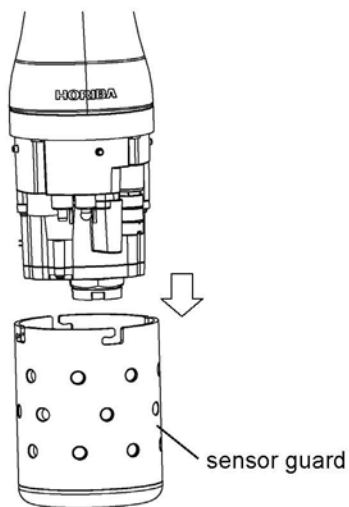

- 2. Remove the transparent calibration cup.
- 3. Fill the transparent calibration cup to the line with pH 4 standard solution.
The transparent calibration cup has With TURB Measurement and Without TURB Measurement gauge lines.

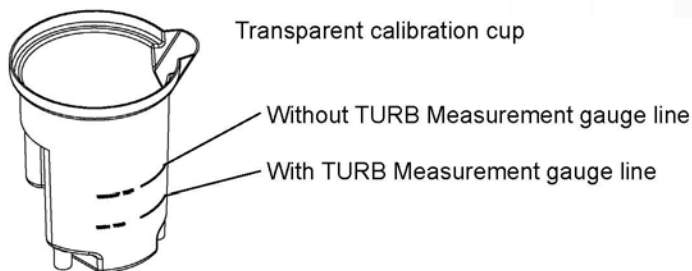

- 4. Press the control unit's CAL key to set the calibration mode.

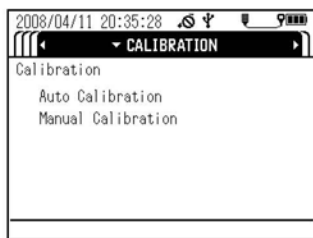

- 5. Press the down (▽) key to move the cursor to "Auto Calibration", then press the ENTER key.

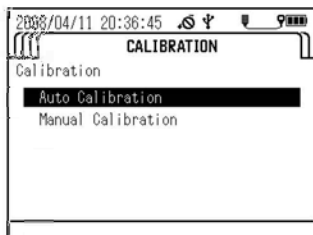

6. Immerse the sensor probe in the transparent calibration cup. Check that the pH sensor, ORP sensor, reference electrode, COND sensor, TURB sensor and temperature sensor are submerged in the pH 4 standard solution and check that there are no air bubbles on the sensor.

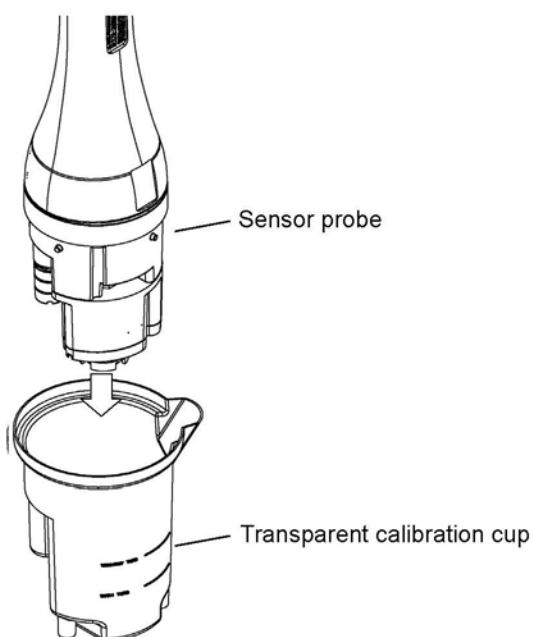
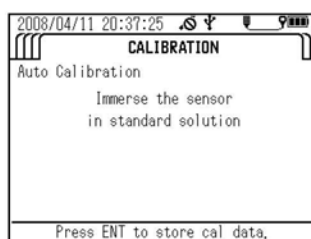

7. With the sensor probe still in the transparent calibration cup, place the transparent calibration cup into the black calibration cup.

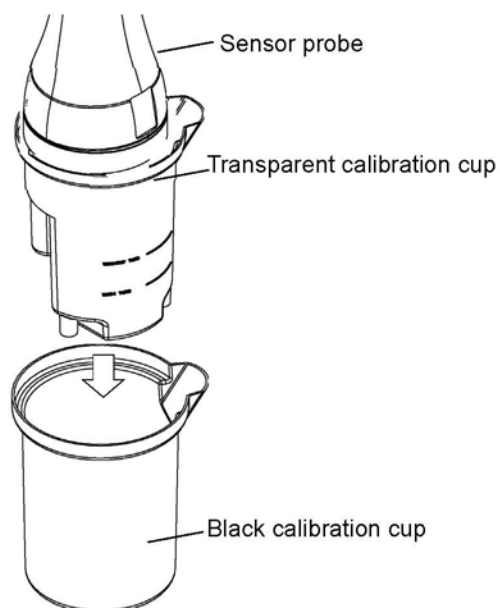

- Wait for 3 minutes or more until all the sensor values have stabilized, and then press the ENTER key to start calibration.

Note

Do not remove the sensor probe from the calibration solution. U-53 turbidity data will display "----" until the calibration is completed.

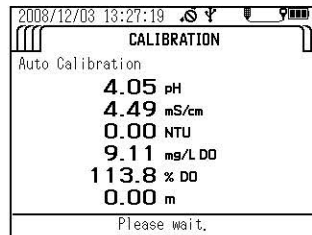

Calibration is finished when the message "Cal complete. MEAS to measure." appears. Press the MEAS key to set the measurement screen, then start measurement.

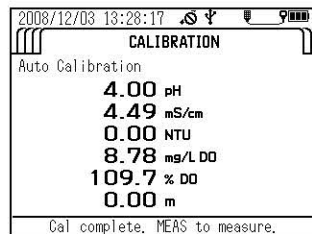

If a calibration error occurs, start calibration after first resolving the issue according to the instructions in " 4.7 Troubleshooting " (page 94).

3.3.2 Manual calibration

The procedures below describe how to calibrate each sensor individually.

Note

The displayed units are the units set by selecting "Unit for report" in the "SETTINGS" screen.

● **Temperature (TEMP) calibration**

- Fill a bucket or similar container with water of a known temperature, and insert the sensor probe in it.
Wait 5 minutes before starting calibration to allow the sensor probe temperature to stabilize.
- Press the control unit's CAL key to set the calibration mode.
- Press the down (▽) key to move the cursor to "Manual Calibration", then press the ENTER key.

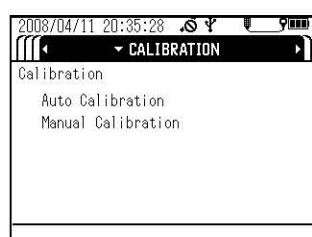

- In the parameter selection screen, move the cursor to "Temp", then press the ENTER key.

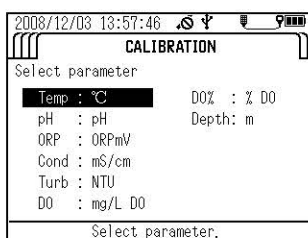

- Press the up (Δ) and down (∇) keys to set the calibration value - the temperature of the water containing the submerged sensor probe.

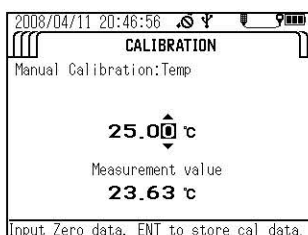

- Check that "Measurement value" has stabilized, then press the ENTER key to start calibration.

Calibration is finished when the message "Cal complete. CNT to measure." appears.

● pH calibration

Note

You can select one calibration point (zero-point calibration) or two calibration points (zero-point calibration and span calibration). Carry out two calibration procedures to ensure good measurement precision throughout all measurement ranges.

- Calibrate the zero point. Wash the transparent calibration cup 2 or 3 times with deionized water, then fill it to the reference line with pH 6.86 standard solution.
- Wash the sensor probe 2 or 3 times in deionized water to remove any dirt, then submerge the sensor probe in the transparent calibration cup.
- Press the control unit's CAL key to set the calibration mode.

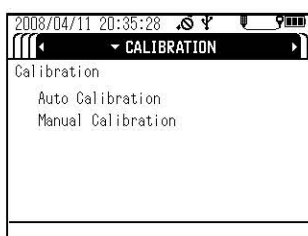

- Press the down (∇) key to move the cursor to "Manual Calibration", then press the ENTER key.

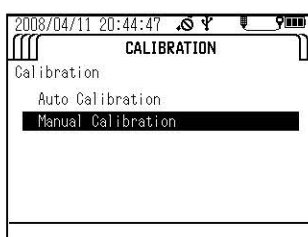

5. In the parameter selection screen, move the cursor to "pH", then press the ENTER key.

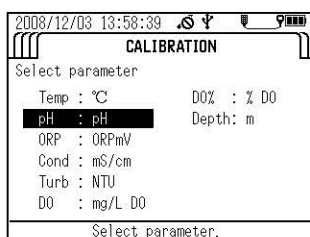

6. Set the number of calibration points, then press the ENTER key.

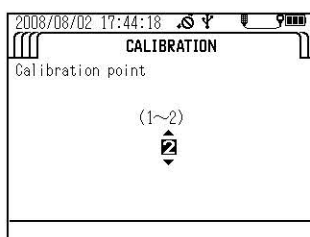

7. Press the up (Δ) and down (∇) keys to set the pH value of the pH 6.86 standard solution containing the submerged sensor probe at the measurement temperature

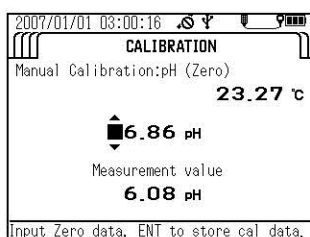

Table 1 Indicated value of HORIBA pH standard solutions at various temperatures (pH)

| Temp. (°C) | pH 4 standard solution Phthalate | pH 6.86 standard solution Neutral phosphate | pH 9 standard solution Borate |
|------------|-------------------------------------|--|----------------------------------|
| 0 | 4.01 | 6.98 | 9.46 |
| 5 | 4.01 | 6.95 | 9.39 |
| 10 | 4.00 | 6.92 | 9.33 |
| 15 | 4.00 | 6.90 | 9.27 |
| 20 | 4.00 | 6.88 | 9.22 |
| 25 | 4.01 | 6.86 | 9.18 |
| 30 | 4.01 | 6.85 | 9.14 |
| 35 | 4.02 | 6.84 | 9.10 |
| 40 | 4.03 | 6.84 | 9.07 |
| 45 | 4.04 | 6.84 | 9.04 |

Table 2 Indicated value of other pH standard solutions at various temperatures (pH)

| Temp. (°C) | pH 7 standard solution Neutral phosphate | pH 10 standard solution Carbonate |
|------------|---|--------------------------------------|
| 0 | 7.12 | 10.32 |
| 5 | 7.09 | 10.25 |
| 10 | 7.06 | 10.18 |
| 15 | 7.04 | 10.12 |
| 20 | 7.02 | 10.06 |
| 25 | 7.00 | 10.01 |
| 30 | 6.99 | 9.97 |
| 35 | 6.98 | 9.93 |
| 40 | 6.97 | 9.89 |
| 45 | 6.97 | 9.86 |

8. Check that "Measurement value" has stabilized, then press the ENTER key to start calibration.
9. Press the ENTER key to start the span calibration procedure when the message "Cal complete. Press ENT to Span cal." appears.

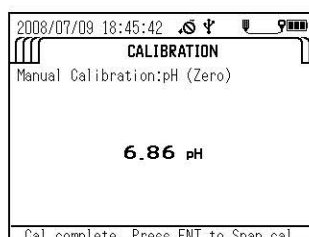

10. Wash the transparent calibration cup 2 or 3 times with deionized water, then fill it to the reference line with pH 4 or pH 9 standard solution.
11. Wash the sensor probe 2 or 3 times in deionized water to remove any dirt, then submerge the sensor probe in the transparent calibration cup.
12. Press the up (Δ) and down (∇) keys to set the pH value of the pH 4 or pH 9 standard solution containing the submerged sensor probe at the measurement temperature.

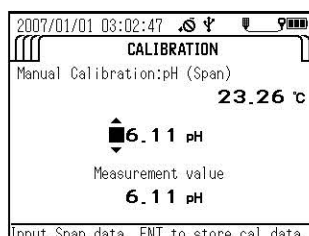

13. Check that "Measurement value" has stabilized, then press the ENTER key to start calibration.

14. Calibration is finished when the message "Cal complete. ENT to manual cal menu." appears. Press the ENTER key to return to the calibration parameter

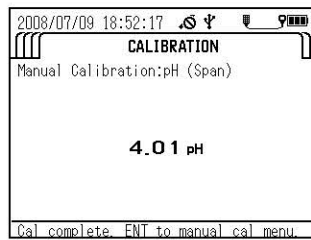

● **ORP calibration**

Note

- If the prepared ORP standard solution is left in open air for one hour or more, the solution may be transformed. For this reason ORP standard solution cannot be stored. Calibrate within one hour of preparing the solution.
- When measuring sample with low concentrations of oxidants and reductants after conducting an operational check using a standard substance, the measured values may not stabilize or the results of measurement might not be repeatable. If this is the case, start the measurement after immersing the sensors in the sample water sufficiently.
- Note that when measuring the ORP of solution with extremely low concentrations of oxidants and reductants, such as tap water, well water, or water treated with purifying equipment, there may be less responsiveness, repeatability, and stability, in general.
- When alkaline ion water is left for 5 minutes, its ORP undergoes changes significantly. Always measure alkaline ion water promptly.

1. Fill a clean beaker with one bag of ORP standard powder No. 160-22 or No. 160-51. Add 250 mL of deionized water and agitate the solution thoroughly (there will be some excess quinhydrone (a black powder) that floats on the surface when agitating the solution). Fill the transparent calibration cup to the reference line with this standard solution.
2. Wash the sensor probe 2 or 3 times in deionized water to remove any dirt, then submerge the sensor probe in the transparent calibration cup.
3. Press the control unit's CAL key to set the calibration mode.
4. Press the down (▽) key to move the cursor to "Manual Calibration", then press the ENTER key.

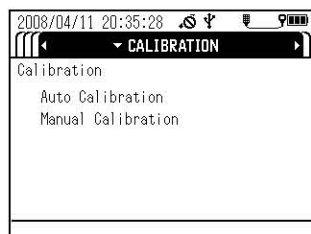

5. In the parameter selection screen, move the cursor to ORP, then press the ENTER key.

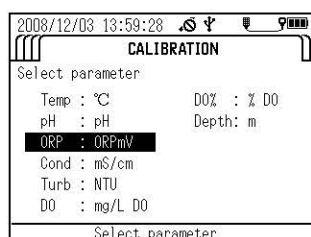

6. Press the up (Δ) and down (∇) keys to set the mV value of the ORP standard solution containing the submerged sensor probe at the measurement temperature.

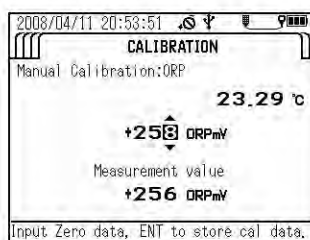

Table 3 Indicated value of ORP standard solution at various temperatures (mV)

| Temperature | 160-22 | 16051 |
|-------------|--------|-------|
| 5 | +274 | +112 |
| 10 | +271 | +107 |
| 15 | +267 | +101 |
| 20 | +263 | +95 |
| 25 | +258 | +89 |
| 30 | +254 | +83 |
| 35 | +249 | +76 |
| 40 | +244 | +69 |

7. Check that "Measurement value" has stabilized, then press the ENTER key to start calibration.
8. Calibration is finished when the message "Cal complete. ENT to manual cal menu." appears. Press the ENTER key to return to the calibration parameter selection screen.

● **Conductivity (COND) calibration**

Note

- To support a wide range of sample concentrations, electrical conductivity is divided into three measurement ranges: 0.0 mS/m to 99.9 mS/m, 0.090 S/m to 0.999 S/m, and 0.9 S/m to 9.99 S/m.
- When manually calibrating conductivity, you can select two calibration points (one zero-point calibration point and a span calibration point for one of the three measurement ranges) or four calibration points (one zero-point calibration point and span calibration points for all three measurement ranges). Carry out the four calibration points to ensure good measurement precision throughout all measurement ranges.
- Make the compensation setting before calibration since this setting is applied during calibration. (Refer to “ 6.5.3 Temperature coefficient ” (page 113)).

1. Prepare the standard solution. Dry Potassium chloride (KCl) powder (high-grade commercially available) at 105°C for two hours, and leave it to cool in a desiccator.
2. Consult the following table and weigh potassium chloride (KCl), then prepare three standard potassium chloride (KCl) solutions following the procedure below.

| Potassium chloride (KCl) standard solution | Conductivity (COND) value | Potassium chloride (KCl) mass (g) at solution temperature of 25°C | Calibration range |
|--|----------------------------|---|--|
| 0.005 mol/L | 71.8 mS/m (0.718 mS/cm) | 0.373 | 0.0 mS/m to 99.9 mS/m (0.00 mS/cm to 0.999 mS/cm) |
| 0.050 mol/L | 0.667 S/m (6.67 mS/cm) | 3.73 | 0.090 S/m to 0.999 S/m (1.00 mS/cm to 9.99 mS/cm) |
| 0.500 mol/L | 5.87 S/m (58.7 mS/cm) | 37.2 | 0.9 S/m to 9.99 S/m (10.0 mS/cm to 99.9 mS/cm) |

3. Dissolve the weighed Potassium Chloride (KCl) in deionized water.
4. Put the dissolved Potassium Chloride (KCl) into a 1 L measuring flask, and fill to the 1 L mark with deionized water.
This completes preparation of the standard solution.
5. Calibrate the zero point. Wash the sensor probe 2 or 3 times in deionized water to remove any dirt, then remove all moisture from the sensor probe (it will be calibrated in air).
6. Press the control unit's CAL key to set the calibration mode.
7. Press the down (▽) key to move the cursor to "Manual Calibration", then press the ENTER key.

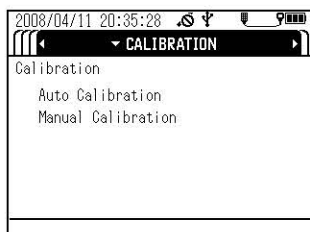

8. In the parameter selection screen, move the cursor to "Cond", then press the ENTER key.

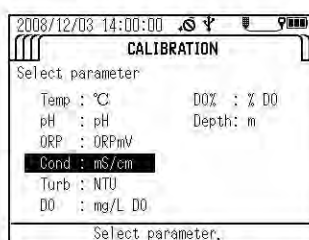

9. Set the number of calibration points, then press the ENTER key.

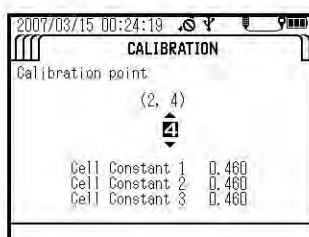

The instructions below assume that four calibration points have been set.

10. Press the up (Δ) and down (∇) keys to set the "Cond" value to 0.0 mS/m (0.000 mS/cm).
11. Check that "Measurement value" has stabilized, then press the ENTER key to start calibration.

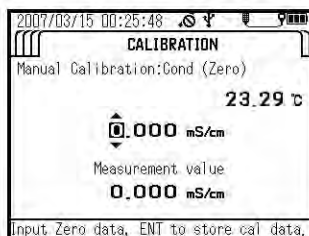

12. When the message "Cal complete. Press ENT to Span cal." appears, press the ENTER key to start the first span calibration procedure.

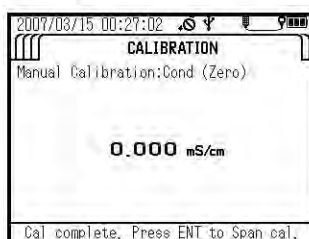

13. Wash the transparent calibration cup 2 or 3 times with deionized water, then fill it to the reference line with 71.8 mS/m (0.718 mS/cm) standard solution.
14. Wash the sensor probe 2 or 3 times in deionized water to remove any dirt, then submerge the sensor probe in the transparent calibration cup.

15. Press the up (Δ) and down (∇) keys to set the "Cond" value to 71.8 mS/m (0.718 mS/cm).

Calibration range = 0 mS/m to 99.9 mS/m (0 mS/cm to 0.999 mS/cm)

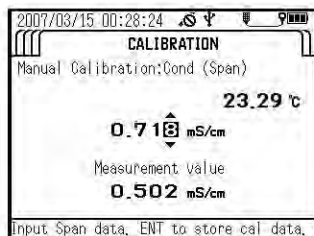

16. Check that "Measurement value" has stabilized, then press the ENTER key to start calibration.
17. When the message "Cal complete. Press ENT to Span cal." appears, press the ENTER key to start the next span calibration procedure.

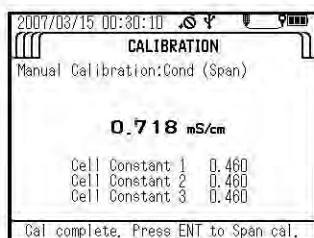

18. Wash the transparent calibration cup 2 or 3 times with deionized water, then fill it to the reference line with 0.667 S/m (6.67 mS/cm) standard solution.
19. Wash the sensor probe 2 or 3 times in deionized water to remove any dirt, then submerge the sensor probe in the transparent calibration cup.
20. Press the up (Δ) and down (∇) keys to set the "Cond" value to 0.667 S/m (6.67 mS/cm).

Calibration range = 0.100 S/m to 0.999 S/m (1.00 mS/cm to 9.99 mS/cm)

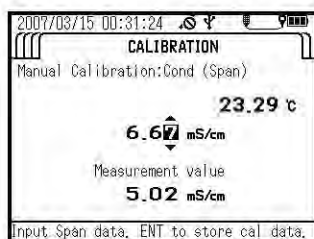

21. Check that "Measurement value" has stabilized, then press the ENTER key to start calibration.
22. When the message "Cal complete. Press ENT to Span cal." appears, press the ENTER key to start the next span calibration procedure.

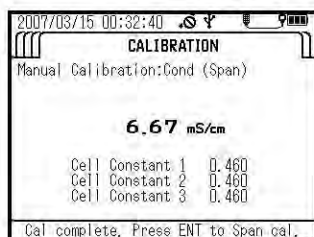

23. Wash the transparent calibration cup 2 or 3 times with deionized water, then fill it to the reference line with 5.87 S/m (58.7 mS/cm) standard solution.
24. Wash the sensor probe 2 or 3 times in deionized water to remove any dirt, then submerge the sensor probe in the transparent calibration cup.
25. Press the up (Δ) and down (∇) keys to set the "Cond" value to 5.87 S/m (58.7 mS/cm).
Calibration range = 1.00 S/m to 10.00 S/m(10.0 mS/cm to 100.0 mS/cm)

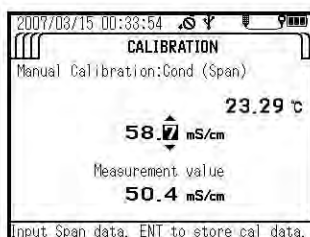

26. Check that "Measurement value" has stabilized, then press the ENTER key to start calibration.
27. Calibration is finished when the message "Cal complete. ENT to manual cal menu." appears. Press the ENTER key to return to the calibration parameter selection screen.

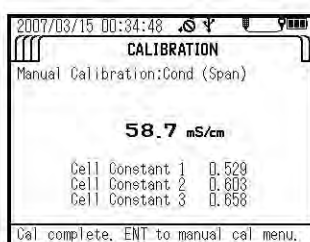

● Turbidity (TURB) calibration

Note

- To support a wide range of sample concentrations, turbidity is divided into three measurement ranges: 0.0 to 9.9 NTU, 10 to 100 NTU, and over 100 NTU.
 - When manually calibrating turbidity, you can select two calibration procedures (one zero-point calibration procedure and a span calibration procedure for one of the three measurement ranges), three calibration procedures (one zero-point calibration procedure and a span calibration procedure for two of the three measurement ranges) or four calibration procedures (one zero-point calibration procedure and span calibration procedures for all three measurement ranges). Carry out the four calibration procedures to ensure good measurement precision throughout all measurement ranges.
 - Always use the calibration cup provided. Using other containers can create effects from ambient light that cause incorrect calibration.
-

● Preparing the standard solutions

Preparing the calibration solution.

1. Weigh out 5.0 g of hydrazine sulfate (commercial special grade or above), and dissolve it in 400 mL of deionized water. Dissolve 50 g of hexamethylene tetramine (commercial special grade or above) in 400 mL of deionized water in another flask.
2. Mix the two solutions and add deionized water until the total solution volume is 1000 mL, and mix well. Store this solution at a temperature of 25°C ±3°C for 48 hours.
The turbidity value (TURB) of this solution is equivalent to 4000 NTU.
3. Dilute 4000 NTU-solution 5 times (use a pipette to measure 50 mL of the 4000 NTU solution and pour it into a 250 mL measuring flask, and fill up to 250 mL meniscus)
The turbidity value (TURB) of this solution is equivalent to 800 NTU.
4. Dilute 800 NTU solution 10 times (use a pipette to measure 25 mL of the 800 NTU solution and pour it into a 250 mL measuring flask, and fill up to 250 mL meniscus)
The turbidity value (TURB) of this solution is equivalent to 80 NTU.
5. Dilute 80 NTU solution 10 times (use a pipette to measure 25 mL of the 80 NTU solution and pour it into a 250 mL measuring flask, and fill up to 250 mL meniscus)
The turbidity value (TURB) of this solution is equivalent to 8 NTU.

Note

Instead of the standard solutions above, you can use other standard solutions of known concentration measured with other standard instruments.

● U-52, U-53, U-54 turbidity calibration

Set the number of calibration points.

You can set between 2 and 4 points.

1. Press the control unit's CAL key to set the calibration mode.
2. Press the down (▽) key to move the cursor to "Manual Calibration", then press the ENTER key.

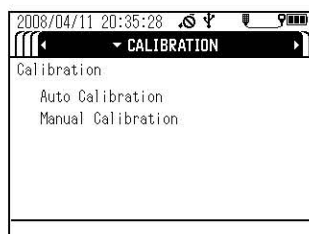

3. In the parameter selection screen, move the cursor to "Turb", then press the ENTER key.

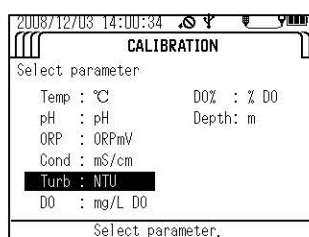

4. Press the up (Δ) and down (▽) keys to set the number of calibration points, then press the ENTER key.

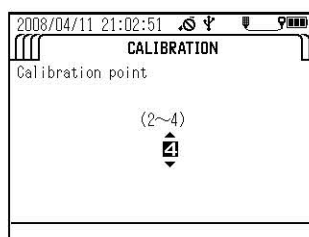

The instructions below assume that four calibration points have been set.

5. Calibrate the zero point. Wash the transparent calibration cup 2 or 3 times with deionized water, then fill it to the reference line with deionized water.
6. Wash the sensor probe 2 or 3 times in deionized water to remove any dirt, then submerge the sensor probe in the transparent calibration cup.
7. Press the up (Δ) and down (▽) keys to set the "Turb" value to 0.0 NTU.

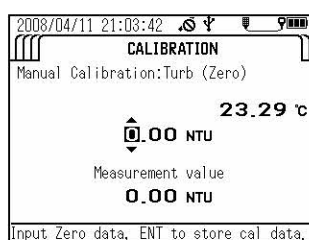

8. Check that "Measurement value" has stabilized, then press the ENTER key to start calibration.

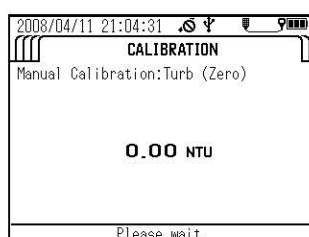

9. When the message "Cal complete. Press ENT to Span cal." appears, press the ENTER key to start the first span calibration procedure.

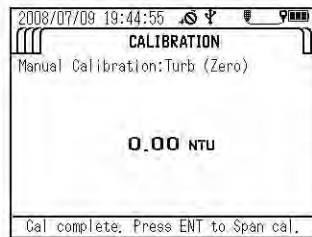

10. Wash the transparent calibration cup 2 or 3 times with deionized water, then fill it to the reference line with 8 NTU standard solution, or a standard solution of known concentration between 0.1 and 10 NTU.
11. Wash the sensor probe 2 or 3 times in deionized water to remove any dirt, then submerge the sensor probe in the transparent calibration cup.
12. Press the up (Δ) and down (∇) keys to set the "TURB" value to 8 NTU, or to the known concentration of the standard solution between 0.1 and 10 NTU. (Input range = 0 NTU to 9.9 NTU (U-52, U-54) or 0 NTU to 9.99 NTU (U-53))

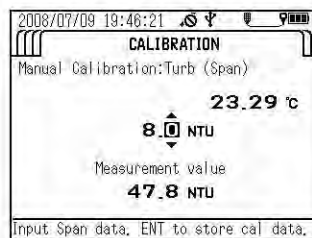

13. Check that "Current measurement value" has stabilized, then press the ENTER key to start calibration.
14. When the message "Cal complete. Press ENT to Span cal." appears, press the ENTER key to start the next span calibration procedure.

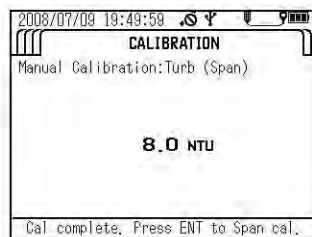

15. Wash the transparent calibration cup 2 or 3 times with deionized water, then fill it to the reference line with 80 NTU standard solution, or a standard solution of known concentration between 10 and 100 NTU.
16. Wash the sensor probe 2 or 3 times in deionized water to remove any dirt, then submerge the sensor probe in the transparent calibration cup.

17. Press the up (Δ) and down (∇) keys to set the "Turb" value to 80 NTU, or to the known concentration of the standard solution between 10 and 100 NTU. (Input range = 10.0 NTU to 99.9 NTU)

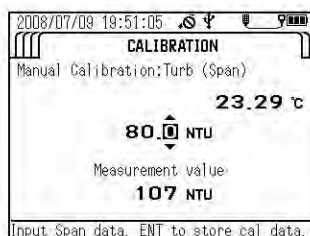

18. Check that "Measurement value" has stabilized, then press the ENTER key to start calibration.
19. When the message "Cal complete. Press ENT to Span cal." appears, press the ENTER key to start the next span calibration procedure.

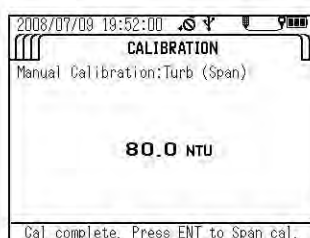

20. Wash the transparent calibration cup 2 or 3 times with deionized water, then fill it to the reference line with 800 NTU standard solution, or a standard solution of known concentration 100 to 800 NTU above.
21. Wash the sensor probe 2 or 3 times in deionized water to remove any dirt, then submerge the sensor probe in the transparent calibration cup.
22. Press the up (Δ) and down (∇) keys to set the "TURB" value to 800 NTU, or to the known concentration of the standard solution 100 to 800 NTU above. (Input range = 100 NTU to 800 NTU (U-52), 100 NTU to 1000 NTU (U-53, U-54))

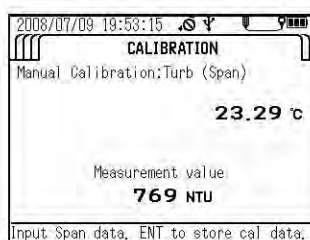

23. Check that "Measurement value" has stabilized, then press the ENTER key to start calibration.
24. Calibration is finished when the message "Cal complete. ENT to manual cal menu." appears. Press the ENTER key to return to the calibration parameter selection screen.



● Dissolved oxygen (DO) calibration

Note

- You can select one calibration procedure (span calibration) or two calibration procedures (zero-point calibration and span calibration). Carry out the two calibration procedures to ensure good measurement precision throughout all measurement ranges.
- Both “DO” and “DO%” are calibrated at the same time.
- It is necessary to prepare new solution before calibration of the Dissolved Oxygen (DO) sensor.
- The calibration cup (included) cannot be used to manually calibrate the DO sensor. Use a suitable bottle in which the DO sensor and the temperature sensor can be immersed.
- Wait at least 20 minutes after turning the system power ON before calibrating the DO sensor.
- Make the compensation setting before calibration since the setting is applied during calibration.
- The DO sensor is affected by flow. When performing span calibration with saturated dissolved oxygen water, move the cable slowly up and down (move the sensor probe at a rate of roughly 20 to 30 cm a second) or agitate the saturated dissolved oxygen water.

1. Prepare the standard solution.

- Add about 50 g of sodium sulfite to 1000 mL of water (either deionized water or tap water) and stir the mixture to dissolve the sodium sulfite in it.
- Pour 1 to 2 liters of water into a suitable flask (either deionized water or tap water). Using an air pump, feed air into the water and aerate the solution until oxygen is saturated.

2. First, calibrate the zero point. Press the control unit’s CAL key to set the calibration mode.

3. Press the down (▽) key to move the cursor to "Manual Calibration", then press the ENTER key.

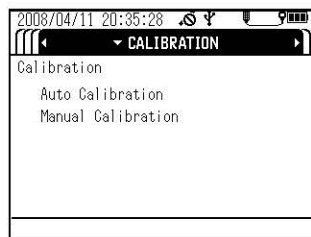

4. In the parameter selection screen, move the cursor to DO or DO%, then press the ENTER key.

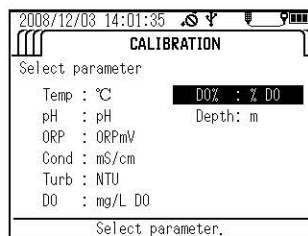
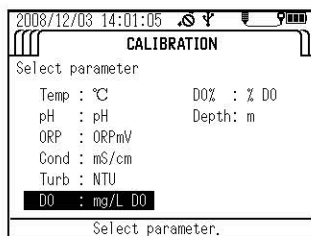

5. Set the number of calibration procedures, then press the ENTER key.

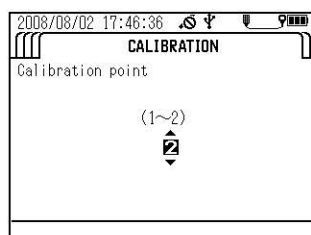

The instructions below assume that two calibration points have been set.

6. Wash the sensor probe 2 or 3 times in deionized water to remove any dirt, then submerge the sensor probe in the bottle.
7. Press the up (Δ) and down (∇) keys to set the DO value to 0.00 mg/L or 0.0%.

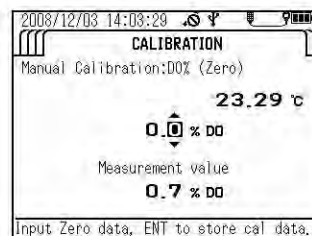
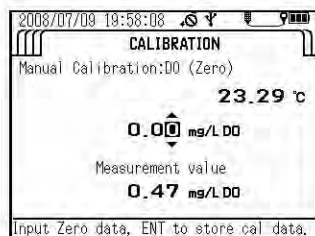

8. Check that "Measurement value" has stabilized, then press the ENTER key to start calibration.
9. When the message "Cal complete. Press ENT to Span cal." appears, press the ENTER key to start the span calibration procedure.

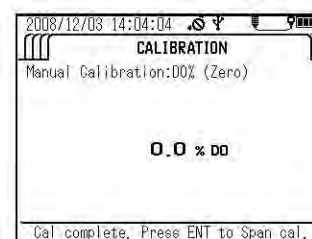
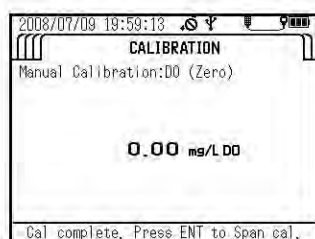

10. Wash the sensor probe 2 or 3 times with deionized water to remove any dirt, then submerge the sensor probe in the container filled with the span solution.
11. Press the up (Δ) and down (∇) keys to set the DO value to the saturated dissolved oxygen value (mg/L) of the water at that temperature or the dissolved oxygen saturation ratio.

Tip

- If atmospheric pressure of the measurement location is not standard atmospheric pressure (1013hPa), input saturated dissolved oxygen value (mg/L) considering the differences of atmospheric pressure. As a rough guide, multiply (Atmospheric pressure of the measurement location(hPa))/(Standard atmospheric pressure(1013 hPa)) by saturated dissolved oxygen value at standard atmospheric pressure.
- In case of calibration by saturation ratio(%), consideration of atmospheric pressure is not necessary. Input "100%" for span calibration.

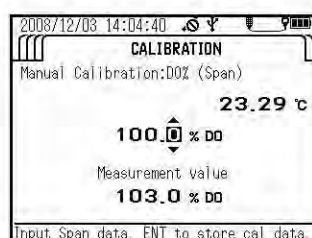
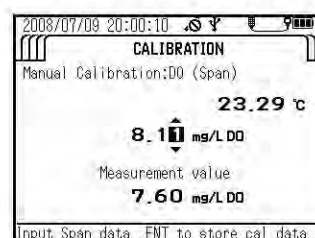

12. Check that "Measurement value" has stabilized, then press the ENTER key to start calibration.

13. Calibration is finished when the message "Cal complete. ENT to manual cal menu." appears. Press the ENTER key to return to the calibration parameter selection screen.

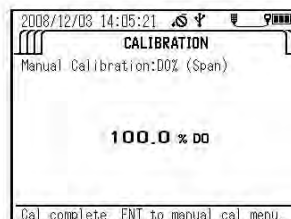
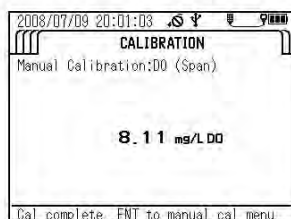

- Amounts of saturated dissolved oxygen in water at various temperatures (salinity=0.0%)

Note

The standards referred for temperature compensation are different by software version.

- Probe software version before 1.51; JIS K0101:1998
- Probe software version after 1.51; ISO5814:2012, K0101:2017

To confirm software version, see "● Version" (page 37).

JIS K0101:1998

| Temp. (°C) | DO (mg/L) | Temp. (°C) | DO (mg/L) | Temp. (°C) | DO (mg/L) | Temp. (°C) | DO (mg/L) |
|------------|-----------|------------|-----------|------------|-----------|------------|-----------|
| 0 | 14.16 | | | | | | |
| 1 | 13.77 | 11 | 10.67 | 21 | 8.68 | 31 | 7.42 |
| 2 | 13.40 | 12 | 10.43 | 22 | 8.53 | 32 | 7.32 |
| 3 | 13.04 | 13 | 10.20 | 23 | 8.39 | 33 | 7.22 |
| 4 | 12.70 | 14 | 9.97 | 24 | 8.25 | 34 | 7.13 |
| 5 | 12.37 | 15 | 9.76 | 25 | 8.11 | 35 | 7.04 |
| 6 | 12.06 | 16 | 9.56 | 26 | 7.99 | 36 | 6.94 |
| 7 | 11.75 | 17 | 9.37 | 27 | 7.87 | 37 | 6.86 |
| 8 | 11.47 | 18 | 9.18 | 28 | 7.75 | 38 | 6.76 |
| 9 | 11.19 | 19 | 9.01 | 29 | 7.64 | 39 | 6.68 |
| 10 | 10.92 | 20 | 8.84 | 30 | 7.53 | 40 | 6.59 |

ISO5814:2012, JIS K0101:2017

| Temp. (°C) | DO (mg/L) | Temp. (°C) | DO (mg/L) | Temp. (°C) | DO (mg/L) |
|------------|-----------|------------|-----------|------------|-----------|
| 0 | 14.62 | | | | |
| 1 | 14.22 | 11 | 11.03 | 21 | 8.91 |
| 2 | 13.83 | 12 | 10.78 | 22 | 8.74 |
| 3 | 13.46 | 13 | 10.54 | 23 | 8.58 |
| 4 | 13.11 | 14 | 10.31 | 24 | 8.42 |
| 5 | 12.77 | 15 | 10.08 | 25 | 8.26 |
| 6 | 12.45 | 16 | 9.87 | 26 | 8.11 |
| 7 | 12.14 | 17 | 9.66 | 27 | 7.97 |
| 8 | 11.84 | 18 | 9.47 | 28 | 7.83 |
| 9 | 11.56 | 19 | 9.28 | 29 | 7.69 |
| 10 | 11.29 | 20 | 9.09 | 30 | 7.56 |

● Span setting values for calibration in air

The software should display these values when auto calibration is performed.

Use this table to input values for manual span calibrations in air.

Tip

The DO measurement value of “air-saturated water” and air are different.

Due to the pressure difference against the membrane in air versus the membrane in water, the measurement value in air is about 10% higher than the value of air-saturated water on average.

Amounts of saturated dissolved oxygen in air at various temperatures

Following tables are applicable only to the air calibration of the U-50 DO sensor. Do not use them for other purpose.

JIS K0101:1998

Air calibration value converted from amounts of saturated dissolved oxygen in water at various temperatures (salinity = 0.0%)

| Temp (°C) | DO (mg/L) | Temp (°C) | DO (mg/L) | Temp (°C) | DO (mg/L) | Temp (°C) | DO (mg/L) |
|-----------|-----------|-----------|-----------|-----------|-----------|-----------|-----------|
| 0 | 15.58 | | | | | | |
| 1 | 15.15 | 11 | 11.74 | 21 | 9.55 | 31 | 8.16 |
| 2 | 14.74 | 12 | 11.47 | 22 | 9.38 | 32 | 8.05 |
| 3 | 14.34 | 13 | 11.22 | 23 | 9.23 | 33 | 7.94 |
| 4 | 13.97 | 14 | 10.97 | 24 | 9.08 | 34 | 7.84 |
| 5 | 13.61 | 15 | 10.74 | 25 | 8.92 | 35 | 7.74 |
| 6 | 13.27 | 16 | 10.52 | 26 | 8.79 | 36 | 7.63 |
| 7 | 12.93 | 17 | 10.31 | 27 | 8.66 | 37 | 7.55 |
| 8 | 12.62 | 18 | 10.10 | 28 | 8.53 | 38 | 7.44 |
| 9 | 12.31 | 19 | 9.91 | 29 | 8.40 | 39 | 7.35 |
| 10 | 12.01 | 20 | 9.72 | 30 | 8.28 | 40 | 7.25 |

ISO5814:2012, JIS K0101:2017

Air calibration value converted from amounts of saturated dissolved oxygen in water at various temperatures (salinity = 0.0%)

| Temp. (°C) | DO (mg/L) | Temp. (°C) | DO (mg/L) | Temp. (°C) | DO (mg/L) |
|------------|-----------|------------|-----------|------------|-----------|
| 0 | 16.08 | | | | |
| 1 | 15.64 | 11 | 12.13 | 21 | 9.80 |
| 2 | 15.21 | 12 | 11.86 | 22 | 9.61 |
| 3 | 14.81 | 13 | 11.59 | 23 | 9.44 |
| 4 | 14.42 | 14 | 11.34 | 24 | 9.26 |
| 5 | 14.05 | 15 | 11.09 | 25 | 9.09 |
| 6 | 13.70 | 16 | 10.86 | 26 | 8.92 |
| 7 | 13.35 | 17 | 10.63 | 27 | 8.77 |
| 8 | 13.02 | 18 | 10.42 | 28 | 8.61 |
| 9 | 12.72 | 19 | 10.21 | 29 | 8.46 |
| 10 | 12.42 | 20 | 10.00 | 30 | 8.32 |

● **Water depth (DEPTH) calibration**

1. Calibrate the zero point. Wash the sensor probe 2 or 3 times in deionized water to remove any dirt, then remove all moisture from the sensor probe (it will be calibrated in air).
2. Press the control unit's CAL key to set the calibration mode.
3. Press the down (▽) key to move the cursor to "Manual Calibration", then press the ENTER key.

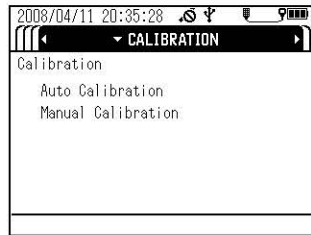

4. In the parameter selection screen, move the cursor to "Depth", then press the ENTER key.

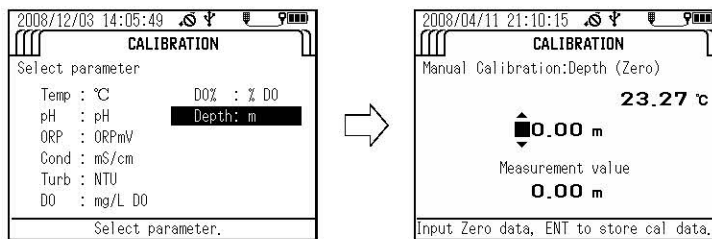

5. Press the up (△) and down (▽) keys to set the "Depth" value to 0.00 m.
6. Check that "Measurement value" has stabilized, then press the ENTER key to start calibration.

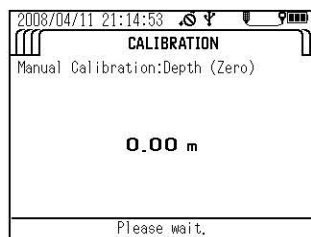

7. Calibration is finished when the message "Cal complete. ENT to manual cal menu." appears. Press the ENTER key to return to the calibration parameter selection screen.

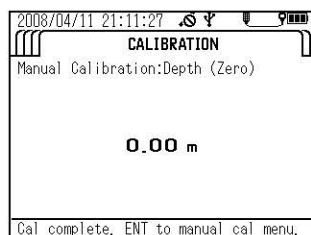

3.4 Measurement

You can perform measurement by either of the methods below.

- Storing data in memory manually with reference to the measurement value (single measurement)
- Having data stored in memory automatically and continuously
 - U-51/U-52/U-54: Interval measurement (minimum memory interval of 10 seconds)
 - U-53: Interval measurement (minimum memory interval of 30 seconds)

Select the measurement method that meets your requirements.

Note

- Lower sensor probe slowly when submerging them in samples.
- Sensors may break if sensor probe are dropped from a height of 1 meter or more.
- Do not submerge sensor probe in water depths of over 30 meters. Sensor probe are only resistant to water pressure of up to 30 meters.
- After turning the power ON, check that the DO readout value has stabilized before starting measurement (takes around 30 minutes).
- If water temperature is different from air temperature by 10°C or more, wait for about 20 minutes after immersing sensor probe into water. (U-54, U-54G)

Tip

- When on the measurement screen, pressing the ENTER key enlarges the display and shows three measured values at a time.
- Pressing the up (▲) and down (▼) keys scrolls through the measured values one item at a time.
- Pressing the ENTER key again reverts to the normal measurement screen display.

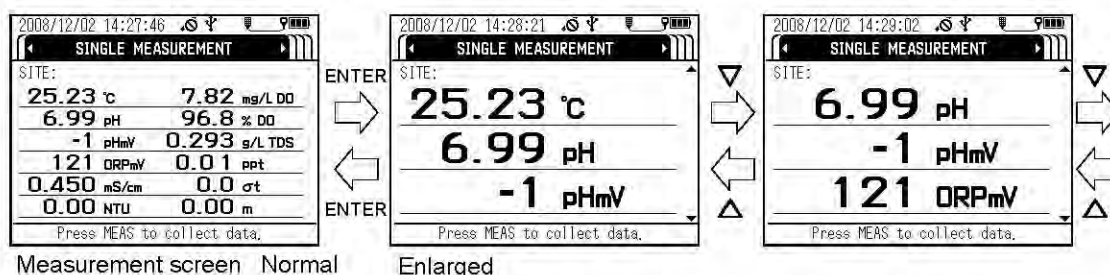

3.4.1 Storing data in memory manually

Follow the steps below to manually store data in memory while referring to the measurement value to check the readout value is stable.

- **U-51/U-52/U-54**
 1. Check that each sensor and sensor guard is mounted.
 2. Check that "SINGLE MEASUREMENT" has been selected in the measurement screen.

| SINGLE MEASUREMENT | |
|-----------------------------|---------------|
| SITE: | |
| 25.23 °C | 7.82 mg/L DO |
| 6.99 pH | 96.8 % DO |
| -1 pHmV | 0.293 g/L TDS |
| 121 ORPmV | 0.01 ppt |
| 0.450 mS/cm | 0.0 σt |
| 0.00 NTU | 0.00 m |
| Press MEAS to collect data. | |

- Submerge the sensor probe in the sample, gently shaking them in the sample to remove any air bubbles from the sensors.

If the sample is non-flowing, move the cable slowly up and down (move the sensor probe at a rate of roughly 20 to 30 cm a second) to ensure that fresh sample is continuously supplied to the DO sensor.

- When the measurement values are stable, press the MEAS key to acquire the 5-second average.

| | |
|---------------------|---------------|
| 2008/12/02 15:24:22 | |
| SINGLE MEASUREMENT | |
| SITE:AAAA | |
| 22.71 °C | 8.34 mg/L DO |
| 6.42 pH | 98.9 % DO |
| 30 pHmV | 0.441 g/L TDS |
| 475 ORPmV | 0.02 ppt |
| 0.689 mS/cm | 0.0 σt |
| 0.00 NTU | 0.00 m |
| Collecting data. | |

- Press the ENTER key to save the held measurement values, or press the ESC key to cancel the operation.

| | |
|--------------------------|---------------|
| 2008/12/02 15:25:06 | |
| SINGLE MEASUREMENT | |
| SITE:AAAA | |
| 22.71 °C | 8.36 mg/L DO |
| 6.42 pH | 99.1 % DO |
| 30 pHmV | 0.441 g/L TDS |
| 475 ORPmV | 0.02 ppt |
| 0.689 mS/cm | 0.0 σt |
| 0.00 NTU | 0.00 m |
| Press ENT to store data. | |



| | |
|-------------------------------------|---------------|
| 2008/12/02 15:25:45 | |
| SINGLE MEASUREMENT | |
| SITE:AAAA | |
| 22.71 °C | 8.30 mg/L DO |
| 6.42 pH | 98.5 % DO |
| 30 pHmV | 0.441 g/L TDS |
| 475 ORPmV | 0.02 ppt |
| 0.689 mS/cm | 0.0 σt |
| 0.00 NTU | 0.00 m |
| Store data complete. Press ESC key. | |

U-53

Note

Do not perform turbidity measurement in air as it may damage the wiper.

U-53 turbidity measurement follows the sequence below. The measurement values are held after each sequence.

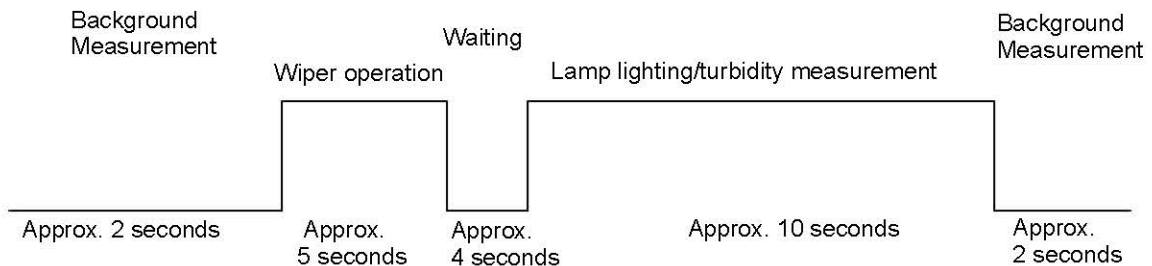

- Check that each sensor and sensor guard is mounted.
- Check that "SINGLE MEASUREMENT" has been selected in the measurement screen.

| | |
|-----------------------------|---------------|
| 2007/01/01 01:59:06 | |
| SINGLE MEASUREMENT | |
| SITE: | |
| 23.53 °C | 10.38 mg/L DO |
| 6.49 pH | 122.2 % DO |
| 4 pHmV | 0.004 g/L TDS |
| 372 ORPmV | 0.00 ppt |
| 0.007 mS/cm | 0.0 σt |
| 0.0 NTU | 0.00 m |
| Press MEAS to collect data. | |

- Submerge the sensor probe in the sample, gently shaking them in the sample to remove any air bubbles from the sensors.

If the sample is non-flowing, move the sensor probe slowly up and down (move the sensor probe at a rate of roughly 20 to 30 cm a second) to ensure that fresh sample is continuously supplied to the DO sensor.

- When the non-turbidity meter measurement values are stable, press the MEAS key to start the sequence above.

| SINGLE MEASUREMENT | |
|--------------------|---------------|
| SITE:AAAA | |
| 22.71 °C | 8.34 mg/L DO |
| 6.42 pH | 98.9 % DO |
| 30 pHmV | 0.441 g/L TDS |
| 475 DRPmV | 0.02 ppt |
| 0.689 mS/cm | 0.0 σt |
| 0.00 NTU | 0.00 m |
| Collecting data. | |

- When the sequence has finished, hold the measurement values. Press the ENTER key to store the held measurement values, or press the ESC key to cancel the operation.

| SINGLE MEASUREMENT | |
|--------------------------|---------------|
| SITE:AAAA | |
| 22.71 °C | 8.36 mg/L DO |
| 6.42 pH | 99.1 % DO |
| 30 pHmV | 0.441 g/L TDS |
| 475 DRPmV | 0.02 ppt |
| 0.689 mS/cm | 0.0 σt |
| 0.00 NTU | 0.00 m |
| Press ENT to store data. | |

→

| SINGLE MEASUREMENT | |
|-------------------------------------|---------------|
| SITE:AAAA | |
| 22.71 °C | 8.30 mg/L DO |
| 6.42 pH | 98.5 % DO |
| 30 pHmV | 0.441 g/L TDS |
| 475 DRPmV | 0.02 ppt |
| 0.689 mS/cm | 0.0 σt |
| 0.00 NTU | 0.00 m |
| Store data complete. Press ESC key. | |

3.4.2 Automatic, continuous measurement

● Interval measurement

- Select the "Interval measurement" measurement setting (see " 3.2.1 Setting measurement methods " (page 19)).
- Press the up (Δ) and down (▽) keys to set the interval value to the desired value (U-51/U-52/U-54: minimum interval: 10 seconds, U-53: minimum interval: 30 seconds), then press the ENTER key.

The measurement screen appears automatically, and the system becomes ready for measurement.

- Check that each sensor and sensor guard is mounted.
- Submerge the sensor probe in the sample, gently shaking them in the sample to remove any air bubbles from the sensors.

If the sample is non-flowing, move the sensor probe slowly up and down (move the sensor probe at a rate of roughly 20 to 30 cm a second) to ensure that fresh sample is continuously supplied to the DO sensor.

- Press the ENTER key to start measurement.

| INTERVAL MEASUREMENT | |
|--------------------------------------|---------------|
| SITE:HGR1BA | |
| 22.76 °C | 8.38 mg/L DO |
| 6.44 pH | 99.6 % DO |
| 28 pHmV | 0.442 g/L TDS |
| 462 DRPmV | 0.02 ppt |
| 0.690 mS/cm | 0.0 σt |
| 0.00 NTU | 0.00 m |
| Interval measuring. ESC to previous. | |

3.5 Data operations

Use the procedures below to retrieve data stored in memory, delete all the data, check the remaining data memory capacity, and check the calibration record.

3.5.1 Displaying data

For maximum efficiency, there are 3 methods of displaying data.

- Displaying the data for a specified site
- Displaying the data for a specified date/time
- Displaying all the data

Use the method that best suits your requirements.

● Displaying the data for a specified site

1. Press the control unit's **POWER** key for about 1 second to turn the power ON.
The "MEASUREMENT" screen appears after about 10 seconds.

| SINGLE MEASUREMENT | |
|--------------------|---------------|
| SITE: | |
| 23.53 °C | 10.38 mg/L DO |
| 6.49 pH | 122.2 % DO |
| 4 pHmV | 0.004 g/L TDS |
| 372 ORPmV | 0.00 ppt |
| 0.007 mS/cm | 0.0 ct |
| 0.0 NTU | 0.00 m |

Press MEAS to collect data.

Note

The operation keys are designed to operate using the pad of a finger, sharp objects can tear the control unit cover damaging the operation keys.

2. Press the right (▷) key 3 times to display the "DATA OPERATION" screen.
3. Press the down (▽) key to move the cursor to "View Data", then press the ENTER key.

| DATA OPERATION | |
|--------------------|--|
| Data Operation | |
| View Data | |
| Delete Data | |
| Data Memory check | |
| Calibration record | |

4. Move the cursor to "Site", then press the ENTER key.

| DATA OPERATION | |
|----------------|--|
| View Data | |
| Site | |
| Date | |
| All | |

5. Press the up (△), down (▽), left (◀) and right (▷) keys to enter the site to retrieve.

6. Move the cursor to "Search", then press the ENTER key.

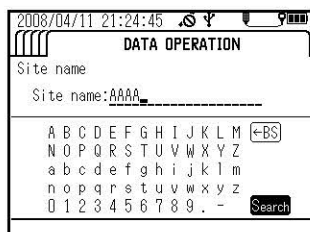

All site names that begin with the entered text are displayed.

The most recently measured data for the entered site is displayed.

7. Press the up (Δ) and down (∇) keys to display earlier data.

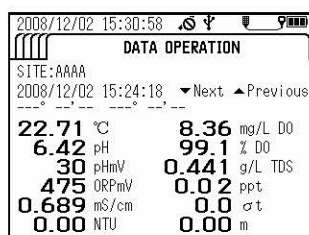

● Displaying the data for a specified date/time

1. Press the control unit's POWER key for about 1 second to turn the power ON.
The "MEASUREMENT" screen appears after about 10 seconds.

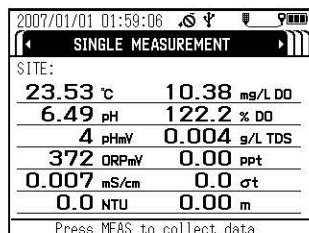

Note

The operation keys are designed to operate using the pad of a finger, sharp objects can tear the control unit cover damaging the operation keys.

2. Press the right (\triangleright) key 3 times to display the "DATA OPERATION" screen.
3. Press the down (∇) key to move the cursor to "View Data", then press the ENTER key.

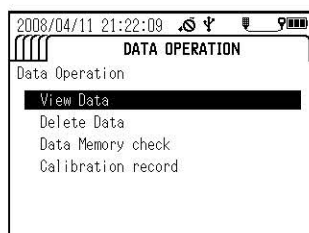

4. Move the cursor to "Date", then press the ENTER key.

5. With the cursor on the Date, press the ENTER key.

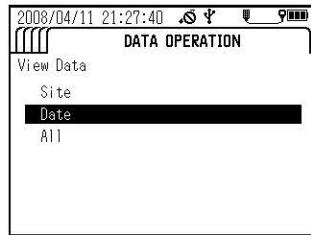

6. Press the up (Δ), down (∇), left (◀) and right (▶) keys to enter the desired date/time, then press the ENTER key to apply the setting.
7. The cursor moves to "Search". Press the ENTER key to start the search.
8. Press the up (Δ) and down (∇) keys to display earlier data.

● **Displaying all the data**

1. Press the control unit's POWER key for about 1 second to turn the power ON. The "MEASUREMENT" screen appears after about 10 seconds.

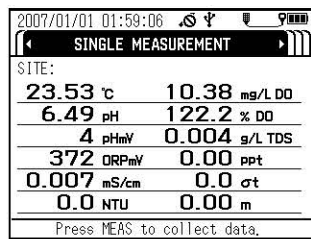

Note

The operation keys are designed to operate using the pad of a finger, sharp objects can tear the control unit cover damaging the operation keys.

2. Press the right (▶) key 3 times to display the "DATA OPERATION" screen.
3. Press the down (∇) key to move the cursor to "View Data", then press the ENTER key.

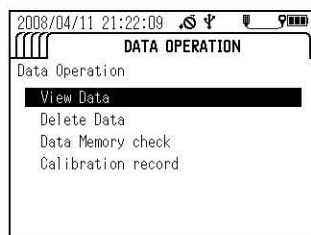

-
4. Move the cursor to "All", then press the ENTER key.
The most recently measured data is displayed.

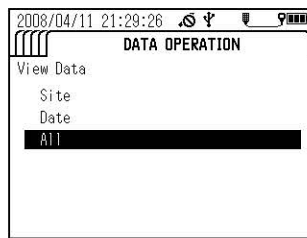

5. Press the up (Δ) and down (∇) keys to display earlier data.